

ANTOM

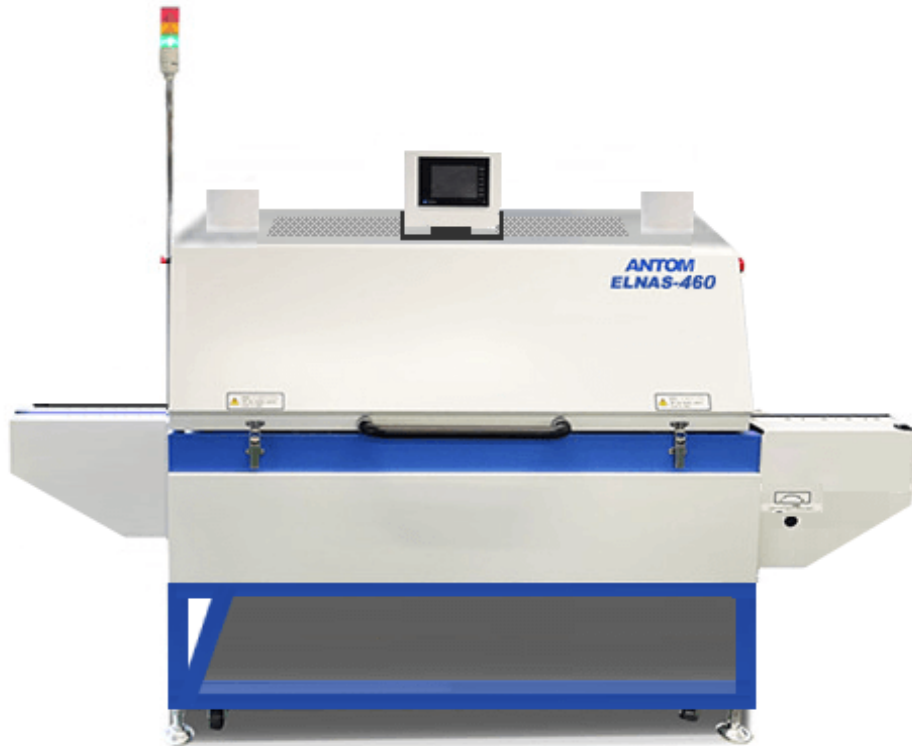

ELNAS-460

- Clearance of 100 mm above and below conveying height
- Ability to collect odors through exhaust ducts at entrances and exits
- Achieving a drastic reduction in drying time by switching from natural drying
- Significant reduction in electricity consumption (approximately 3Kw when stable)

Antom Co., Ltd.

ELNAS-460

External dimensional drawing

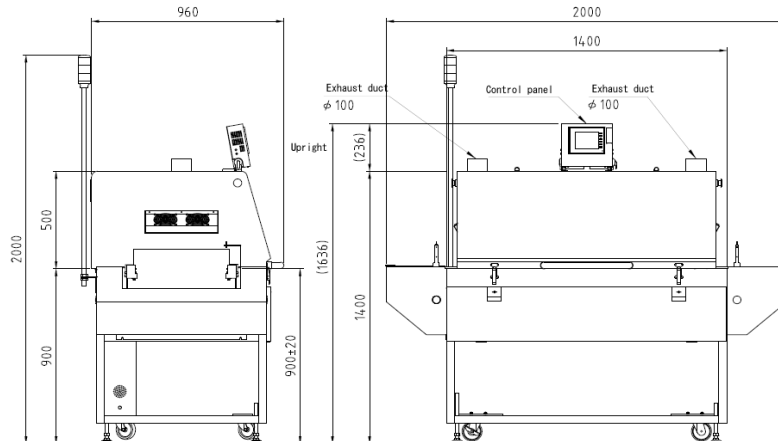

Basic specifications

Number of zones	5 heating zones
Heating method	Upper hot air + far infrared heating
Maximum set temperature	Upper 200 °C
Effective board width	460mm
Transport method	pin chain transport
Transport speed	0.5~2.0m/min
Effective height of parts	Upper surface 100mm / Lower surface 100mm
Supported language	Japanese / English
Path line	900 ± 20mm
Input power supply	AC200V 3 φ 16kVA 47A
Device dimensions	L2,000 × D960 × H1,400mm
Device weight	400kg

Option

lower far infrared heating	Various reflow checkers	
Memory card (100 types of storage)	Cooling conveyors and transfer conveyors	
Overheat prevention device	Change paint color	
Uninterruptible power system		
Circulation fan stop detection		
Hood interlock		
Emergency stop button position change		

※We accept consultations on various customizations other than the above specifications.

Please feel free to contact us for price, delivery date, profile measurement, actual machine tour, demonstration implementation, etc.

Antom Co., Ltd. 893-1 Kawamukai-cho, Tsuzuki-ku, Yokohama-shi, Kanagawa 224-0044

TEL : +81-45-476-3461

WEB : <https://antom.co.jp>