

ANTOM



ECC-600

- Conveyor type conveyor ideal for cooling after heat treatment due to triple fan structure
- Supports pin chain transport with high heat resistance (optional)
- A hold stopper can be attached to prevent the work from falling (optional)
- Various customization correspondence consultation is possible

Antom Co., Ltd.

ECC-600

External dimensional drawing

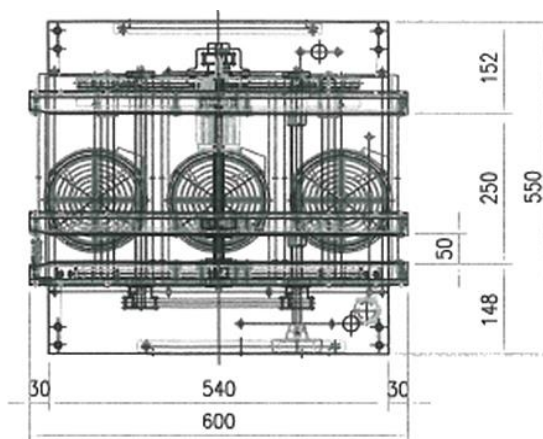
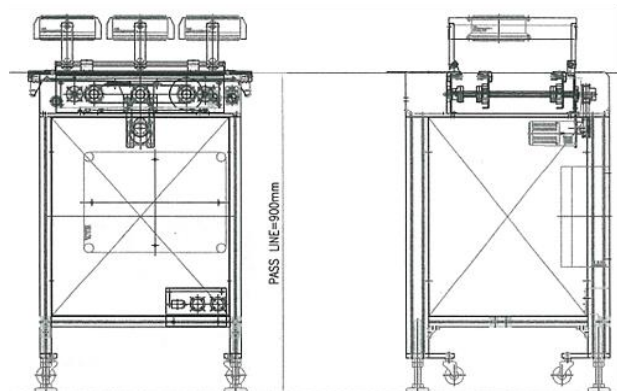

basic specifications

Model name	ECC-600
Effective board width	50~250mm
Path line	900mm (+50/-50)
Input power supply	AC100V
Belt type	Habadit flat belt
Operation method	Button switch
Device size	L600×W500×H900mm
weight	70kg

option

Automatic width conveyor adjustment
Touch panel operation specifications
Signal light
Transport width expansion (MAX460mm)
Compatible with various safety specifications
Work hold stopper
Conveyor speed controller
Various customization support

Triple fan cooling structure



Pin chain specifications (option)

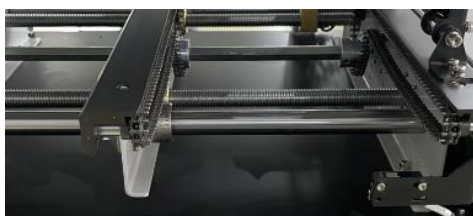

Freely adjust the angle



We have a demo machine, so please feel free to contact us if you would like to experiment or tour.

※Photos, drawings, specifications, dimensions, etc. described in this catalog are subject to change without notice for improvement.

Please feel free to contact us for price, delivery date, profile measurement, actual machine tour, demonstration implementation, etc.

Antom Co., Ltd. 893-1 Kawamukai-cho, Tsuzuki-ku, Yokohama-shi, Kanagawa 224-0044

TEL : +81-45-476-3461

WEB : <https://antom.co.jp>